

SD200/160



SPECIFICATIONS

Pressure:	200 bar / 2822 psi
Water volume:	16 l/min / 960 l/h
Pump:	Cat 5CP 3120
Max. temperature:	130°C
Engine manufacture:	Kubota
Engine power:	10,4 kw / 13,9 hp
Fuel tank:	75 l
Water tank:	7 l
Dimensions LxWxH:	120x80x85 cm
Weight:	250 kg

SAFETY SYSTEM WITH ERROR INDICATION

Low water level

Oil pressure

Engine temperature

Overheat safety

Flame surveillance

The machine is only delivered as a hot water machine

STANDARD EQUIPMENT

Spray gun and lance

10 m high-pressure hose

EXTRA EQUIPMENT – FACTORY MOUNTED

Water tank 360 l

Water tank 700 l

Water tank 1000 l

20 m automatic hose reel

50 m manually or automatic hose reel

ACCESSORIES

Floor tools

Wall tools

Turbo-nozzles

Spray guns and lances

Chewing gum removal tool

Shute cleaner

Pipe cleaning nozzles

Wet sandblasting

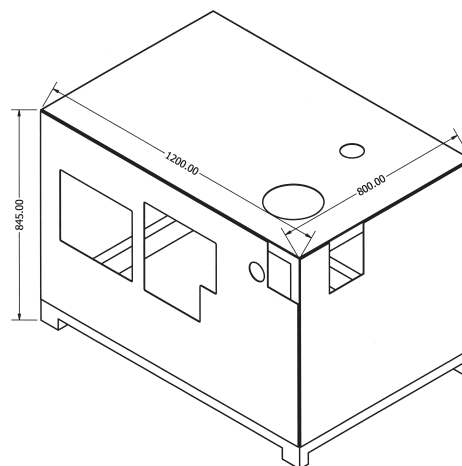

SD200/160



ADVANTAGES

- Compact and handy
- Powerful machine in high quality
- Classic design
- Fits into a small van
- Large accessory program
- Large amount of knowhow and experience as back-up
- Extensive service

ACCESSORIES

Floor tools:



Wall tools:



Turbo nozzles:



Spray guns and lances:



Chewing gum cleaners:



Chute cleaners:



Pipe cleaning nozzles:



Wet sandblasting:

